

F007-EM Fingerprint & RFID Access Controller
User Manual

F007-EM Simplified Instruction

Function description	Choose from the relevant functions below and input
Enter the programming mode	*- 888888 - #, then you can do the programming (888888 is the default factory master code)
change the master code	0 - new code - # - repeat the new code - # (code: 6-8 digit)
Add fingerprint user	1– Fingerprint – repeat Fingerprint - # (can add Fingerprints continuously)
Add card user	1– Card - # (can add Cards continuously)
Delete user	2 – Fingerprint - # 2 – Card -# (can delete Users continuously)
Exit from the programming mode	*
How do release the door	
Fingerprint User	Put the Finger on the fingerprint sensor for 1 second
Card User	Read card

F007- EM Fingerprint& RFID Access Controller

1, Introduction

F007-EM is the new member of F Series Standalone Fingerprint access control, as traditional it is in metal shell, anti-vandal, supports fingerprint, besides, F007-EM support RFID card (125KHZ EM card) and wiegand interface. The high security and more powerful feature make it an ideal choice for door access.

User capacity 2160, including 160 fingerprint users and 2000 RFID card users. With the flexible user capacity, it is suitable to be installed from small house such as personal rooms, shops, office to public place such as large factories, companies.

By Remote control or Master card for programming, it is so user friendly that anyone can use it.

2, Main Feature;

- Metal shell, anti-vandal
- User capacity: 2160
- 160 Fingerprint users, 2000 RFID card users
- Wiegand 26 output; wiegand 26 input
- Besides standalone, it can connect to other controller as the slave reader
- 2 pcs F007-EM can interconnect; 2 pcs F007-EM can be interlocked;
- Remote infrared programmer; Manager card for programming
- Anti-magnetic & lock output current short protect;
- So easy for connection of the lock: only 2 wires output, selecting lock type by programming menu;
- Support connecting any card readers with wiegand interface, such as HID, Mifare, EM
- Full of 2160 users, searching speed <0.1 S.

3, Install, wiring and fixation

3.1, Install and wire

- Open the real plate from the front cover
- Drill 4 holes on the wall for screws and 1 hole for cable.
- Fix the real plate on the wall firmly with 4 flat head screws.
- Thread the cable through the cable hole, wiring, plug the cable harness
- Attach the front cover to the real plate

Terminal Wire Connector Function			
1	D0	Green	Wiegand output, input signal wire D0
2	D1	White	Wiegand output, input signal wire D1
3	ALARM	Grey	connecting to the negative pole of the alarm equipment
4	OPEN	Yellow	To connect to one part of Exit Button
5	D_IN	Brown	Door Contact input,

6	12V	Red	(+) 12Vdc Positive Regulated Power Input
7	GND	Black	(-) Negative Regulated Power Input
8	VSS	Blue	the negative pole of the controller, connect to the other part of Exit button and door contact
9	L-	Purple	Connect to the negative pole of the Lock
10	L+/Alarm+	Orange	Connect to the positive pole of the lock and alarm equipment

Note: Do not power on until all wiring has been completed.

3.2 Intramural interface circuit

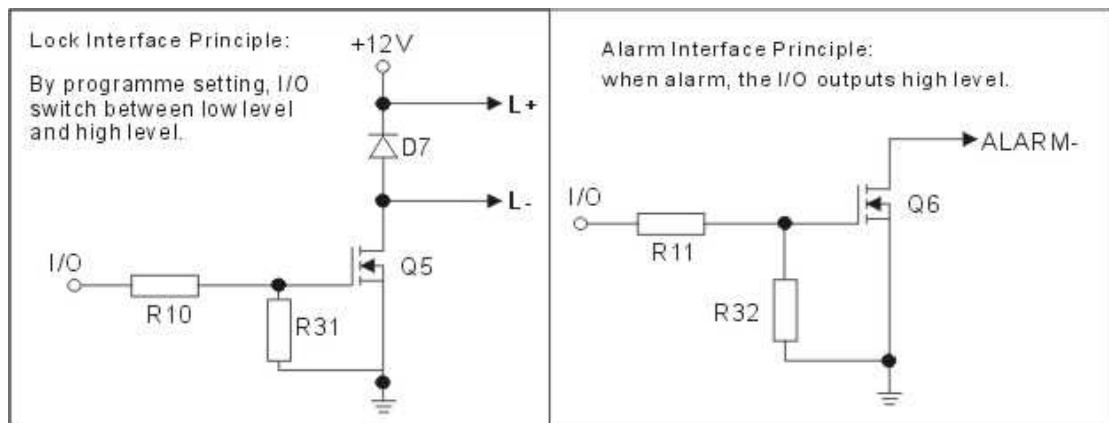

3.3 Method of Reset to Factory default setting and re-register Manager cards

Power off, press the RESET key (SW14) on the PCB, hold it and power on, release it until hear two short beeps, the LED shines in orange, then read any two EM cards, after that the LED turns in red, means reset to factory default setting successfully. Of the two EM cards read, the first one is Manager add card, the second one is Manager delete card.

Remarks: Reset to factory default setting, the users' information enrolled is still retained. When reset to Factory setting, the two Manager cards must be re-enrolled.

3.4 Connection diagram

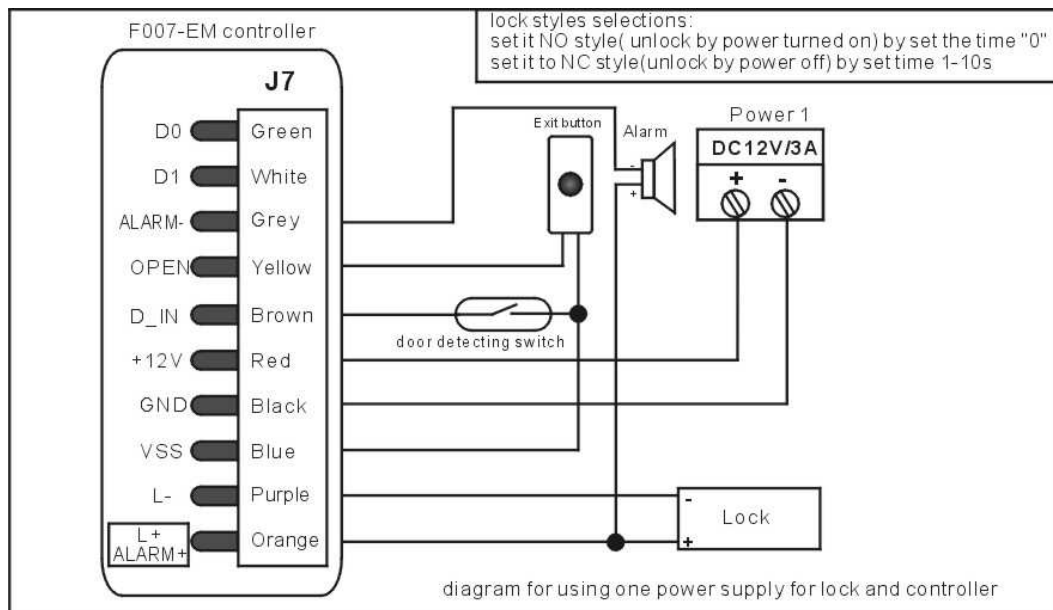

Remark:

F007-EM can connect both types of the locks directly, no matter it's Fail secure (unlock when power on) or Fail safe (unlock when power off). Please check Manager Operation – Item 5 for the lock setting.

4, Manager Operation

There are 3 ways to add and delete users: **1, by Manager card;** **2, by remote control;** **3, by Manager fingerprint**

1, By Manager Card (the most convenient way)

1.1 Add Fingerprint user

Manager add card Enter 1st User Fingerprint Twice 2nd User Fingerprint Twice ... Manager add card

Note: When add fingerprint, please input each fingerprint twice, during which the LED shines red then turn green, means the Fingerprint is enrolled successfully. When delete fingerprint, just input it once

1.2 Add Card user

Manager add card 1st User card 2nd User card ... Manager add card

Remark: Fingerprint user ID is 3-162, Card user ID is 163~2162, when add fingerprint or Card by Manager card, it is produced automatically from 3-160 or 163 to 2162. (ID 1, 2 are belong to Manager fingerprint)

1.3 Delete users

Manager delete card card OR Fingerprint once ... Manager delete card

To delete more than 1 card or fingerprint, just input card or fingerprint continuously.

Note: When delete fingerprint, please input it once.

2, By Remote Control

Enter into programming mode:

* [Manager Password] #. Default Manager Password: 888888

Remarks: All the steps below must be done after enter into programming mode.

2.1 Change Manager Password:

0 [New Password #] [Repeat New Password #]

Remark: The manager password must be 6~8 digit number.

2.2 Add Users:

a) ID number - Auto generation

To add fingerprint users: 1 [input one fingerprint twice] #

(To add more than one fingerprints, just input finger continuously)

To add card users: 1 [Card #] Or 1 [the Card Number (8 digit)] #

(To add more than one card, just input cards or Card number continuously)

Note: when add card users, it can just enroll the card number and don't have to enroll the card itself. The card number is the 8 digit printing on the card.

In the same way, when delete card users, it can just enroll the card number to delete it and don't have to get the card if it is lost.

b) ID number - Appointment

To add fingerprint users: 1 [ID number] # [User Fingerprint] #

(Fingerprint User ID number can be any digit between 3- 162, but one ID number to one user)

To add fingerprint users continuously:

1 3 # [1st User Fingerprint] 4 # [2nd user fingerprint]N # [Nth user fingerprint] #

To add card users: 1 [ID number] # [Card #]

Or 1 [ID number] # [the Card Number (8 digit)] #

(Card User ID number can be any digit between 163- 2162, but one ID to one Card)

To add card continuously: 1 163 # [1st Card] 164 # [2nd Card]N # [Nth Card] #

Or 1 163 # [1st Card Number] 164 # [2nd Card Number]N # [Nth Card Number] #

2.3 Delete users:

Delete fingerprint users: 2 [fingerprint once] #

Delete card users: 2 [Card #] Or 2 [Card Number] #

To delete users continuously: just input fingerprint or card continuously

If delete users by ID

2 [User ID] #

Remarks: When delete users, the Master can just delete its ID number and don't have to input fingerprint or card. It is the good option to delete if the users were left or cards lost.

2.4 To save and exit from the programming mode: *

3, By Manager Fingerprint

Enter into programming mode:

* [Manager Password] #.

Add Manager fingerprint:

1 1 # input fingerprint twice 2 # input another fingerprint twice *

ID number 1: Manager add fingerprint

ID number 2: Manager delete fingerprint

The first Fingerprint: Manager add Fingerprint, it is to add the users

The second Fingerprint: Manager delete Fingerprint, it is to delete users

To add user:

Fingerprint: [Manager add Fingerprint] [Input User Fingerprint twice] [Repeat Manager add Fingerprint]

Card: [Manager add Fingerprint] [Card] [Repeat Manager add Fingerprint]

To add users continuously

Fingerprint: [manager's add fingerprint] [1st user fingerprint] [2nd user fingerprint] ... [Nth User Fingerprint] [Manager's add fingerprint]

Card: [Manager add Fingerprint] [Card 1] [Card 2] [Repeat Manager add Fingerprint]

To delete Fingerprint users

[manager's delete fingerprint] [1st user fingerprint] [2nd user fingerprint] ... [Nth User Fingerprint] [Manager's delete fingerprint]

To delete Card users

[Manager's delete fingerprint] [Card 1] [Card 2] [Manager's delete fingerprint]

4. Delete all the users

* [manager password] # 20000 # *

Note: This will delete all fingerprints, cards, including Manager Fingerprint but except Manager Card, before this operation it is suggested to make sure the data is un-useful.

5, Lock style setting and door relay time setting

Fail secure (unlock when power on) : * [manager password] # 4 [0~10] # *

Fail safe (unlock when power off): * [manager password] # 5 [1~10] # *

Remarks: In programming mode, press 4 is to choose Fail secure lock, 0-10 is to set door relay time 0-10 seconds; press 5 is to choose Fail safe lock, 1-10 is to set door relay time 1- 10 seconds. (Factory default setting is Fail safe lock, relay time 5 seconds.)

6 Setting - Door open detection

* [manager password] # *

6 0 # to disable this function (factory default setting)

6 1 # to enable this function

When enable this function:

- If open the door normally, but not closed after 1 minute, the inside Buzzer will alarm automatically, the alarm will be off itself after 1 minute

- b) If the door was opened force, or the door was not opened in 20 seconds after lock was released, the inside Buzzer and outside Siren will both alarm.

7. Setting - Security Status

* **manager password** #

Normal status: 7 0 #* (Factory default setting)

Lock on status: 7 1 #* In 10 minutes, if there' s 10 times invalid card or wrong Password, the device will lock on for 10 minutes.

Alarm status: 7 2 #* In 10 minutes, if there' s 10 times invalid card or wrong Password, the device will alarm.

8 Remove Alarm

When the device is in alarm (from built-in buzzer, alarm equipment outside), to remove it:

Read valid user's card or fingerprint or Manager Fingerprint or card or Manager Password - # (Any of the method above can remove the alarm.)

9 Two devices interlock setting

* **manager password** #

8 0 #* to disable this function (factory default setting)

8 1 #* to enable this function

10 Setting Alarm signal output time

* **manager password** # 9 0~3 # *

Alarm time is 0-3 minutes for option, factory default setting 1 minute.

5, User Operation

User to release the door

Card user: Read card

Fingerprint user: Input Fingerprint

6, Sound and Light indication

Operation Status	LED	Finger Sensor	Buzzer
Reset to factory default setting	Orange	-	Two short ring
Sleeping mode	Red shines slow	-	-
Stand by	Red shines slow	Shine	-
Enter into programming mode	Red shines	-	Short Ring
Exit from programming mode	Red shines slow	-	Short Ring
Wrong operation	-	-	Three short ring
Open the door	Green shines	-	Short Ring
Alarm	Red shines fast	-	Alarm

7, Technical sheet

Supply Voltage	12VDC±10%
Sleeping Current	<20mA
Stay Current	<90mA
Temperature	-15℃-60℃
Humidity	20%RH-95%RH
Memory capacity	2160
Fingerprint capacity	160
Card capacity	2000
Card type	125KHZ ID card
Card reading distance	50 ± 30 mm
Lock output load capacity	20A
Alarm output load capacity	20A
Resolution	450 DPI
Fingerprint input time	<1S
Identification time	<1S
FAR	<0.001%
FRR	<0.1%
Dimensions	110L*70W*30H(mm)
N/W	500g
G/W	800g

8, Packing list

Description	Quantity	Remark
Door access machine-F007	1	
Infrared remote control	1	
Master card	2	One for add, the other for delete
User Manual	1	
Security Screws (Φ3*7.5mm)	1	To fix the front case to the back case
Screw driver	1	
Self tapping screws (Φ4*25mm)	4	Used for fixing
Pastern stopper (Φ6*25mm)	4	Used for fixing

9, Two devices interconnected Function

1, F007-EM works as slave reader, connecting to Controller

F007-EM supports wiegand output, it can be connected to the controller which support wiegand 26 input as its slave reader, the connection diagram is as figure 1

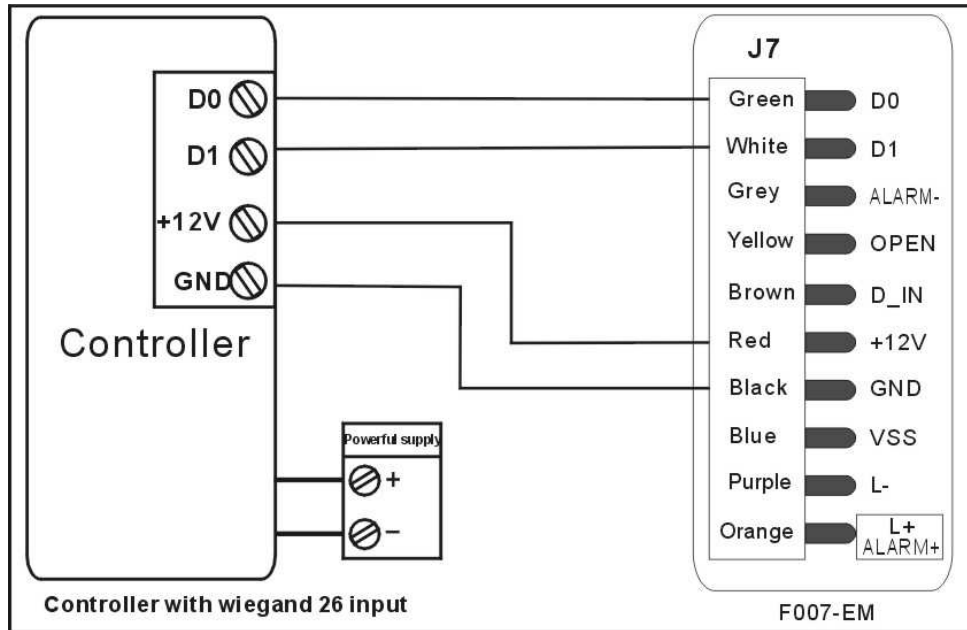

If the controller is PC connection, the users ID can be shown in the software.

- a), Card user, its ID is the same as the card ID number;
- b) Fingerprint user, its ID is the combination of device ID and fingerprint ID

The device ID is set as below:

* [manager password] # [3] [device ID] # *

Note: Device ID can be any digit of 0-255

For example: device ID was set 255, fingerprint ID is 3, then its ID to the controller is 255 00003.

2, F007-EM works as Controller, connecting slave reader

F007-EM supports wiegand input, any card reader which support wiegand 26 interface can connect to it as its slave reader, no matter it is ID card or IC card. The connection is showed as Finger 2. when add cards, it is required to do it at the slave reader, but not controller(except EM card reader, which can be added on either reader or controller)

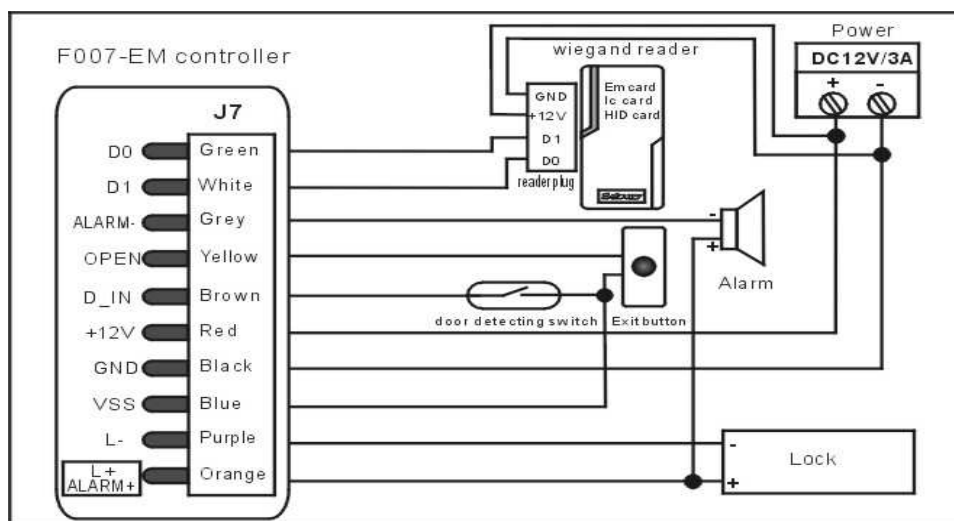

3. Two F007-EM interconnected - single door

Wiegand output, Wiegand input: The connection is showed as Figure 3. One F007-EM installed inside the door, the other outside the door, two devices interconnect. Either device acts as the controller and reader at the same time. It has below feature:

- 2.1 Users can be enrolled on either of the device. The information of the two devices can be communicated. In this situation the user capacity for one door can be up to 4320. Each user can use fingerprint or password for access.
- 2.2 The setting of the two F007-EM must be the same. If the master password was set different, the user enrolled in the outdoor unit can't access from outside.

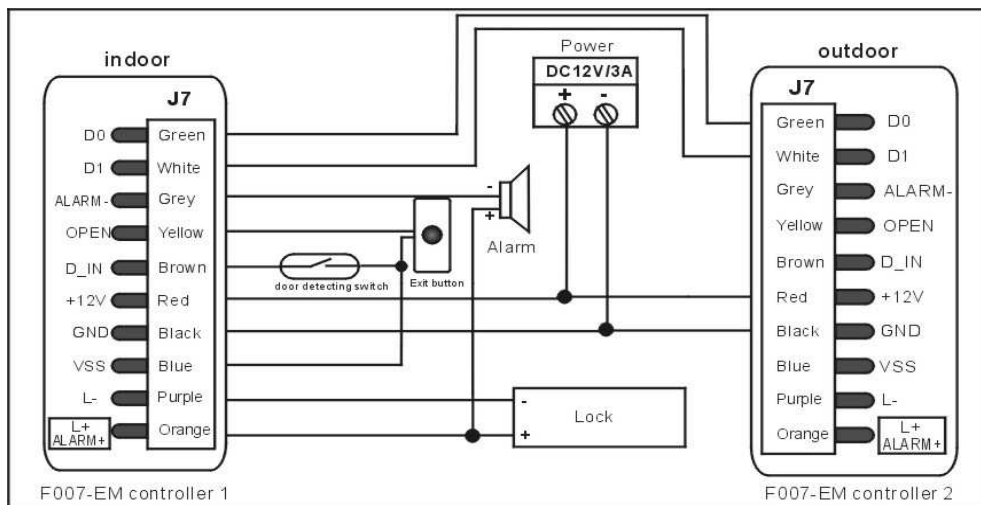

4. Two device interconnected & interlocked – two doors

The connection is showed as Figure 4, for the two doors, each door install one controller and one lock related. The interlocked function will go when either door is opened, the other door is locked forced, only close this door, the other door can be opened.

The interlocked function is mainly using in bank, prison, and other places where require higher security. Two doors are installed for one access.

The user enters fingerprint or card on controller 1, the door 1 will open, the user enters, and close door 1, only after that, the user can open the second door by entering fingerprint or card on second controller.

